

HONDA CB750F



1/12 MOTORCYCLE SERIES



★This kit was designed with the full cooperation of Honda Motor Co., Ltd.
★Dieser Kit wurde in Zusammenarbeit mit der Honda Motor Co., Ltd. entworfen.

The Honda CB750F Motorcycle appeared on the Japanese market in June 1979 and was shortly to become the best seller in the 750 class. Just ten years prior to their 750F release, Honda opened up the field of multicylinder bikes with their now famous four cylinder CB750. Honda had won several Grand Prix motorcycle races with multi-cylinder bikes, and the CB750 was based upon these experiences. The engines worked flawlessly and provided very smooth power, and so shocked the industry that shortly many of the famous makers produced four cylinder large cubic motorcycles. Honda, of course, held the number one position in sales for many years, but then Kawasaki released their "Z" series DOHC 4 cylinder 750 bikes, and took over the number one position, relegating Honda to 2nd place. Honda, however, did not take this set back for long, and continued to improve their engines, and in 1979 released a CB750K DOHC with four valves per cylinder, a powerful 68hp, and new body styling. It was not long before Honda was again number one! The CB750F, released in June 1979 was styled after the very popular European Honda CB900F which had been copied from their racing RCB bike. This styling was new to stock motorcycles in the world. With the low positioned handle bars and rear positioned foot rests, allowed a "slouched" riding posi-

tion. This style is setting the standard for the eighties.

The CB750F is powered by a 4 cylinder DOHC 748cc engine with 4 valves per cylinder, and the 1981 version produces 70 brake horsepower. The bike has a double cradle frame of welded steel tubing, semi-air front suspension system, and FQV damped rear coils. Braking utilizes the dual piston caliper system, with dual discs in front and a single disc at the rear. A newly designed racing type front fender with spoiler has proved to be very popular among bike enthusiasts. The overall styling of that unveiled in 1979, with the smooth flowing lines from tank to tail light have been retained, and it is likely that this fine motorcycle will stay at the forefront of sales for years to come.

* * *

Die Honda CB750F kam im Juni 1979 auf den japanischen Markt und wurde ein Bestseller in der Klasse 750. Bereits 10 Jahre vorher eröffnete Honda mit dem Erscheinen der CB750 das Feld der Mehrzylinder-Motorräder durch diese Vierzylinder-Maschine. Honda gewann mit diesem Motorrad mehrere Grand Prix. Der Motor arbeitete fehlerfrei und entwickelte eine erstaunliche Kraft; und so war die gesamte Motorradindustrie etwas geschockt und kurze Zeit später brachten alle namhaften Hersteller selbst Maschinen mit 4 Zylindern

auf den Markt. Viele Jahre lang war Honda die Nummer Eins auf dem Markt, aber dann kam Kawasaki mit seiner Z-Serie DOHC 4-Zylinder 750 und übernahm den ersten Platz. Honda aber blieb nicht lange auf dieser Stelle, verbesserte seine Motoren und kam 1979 mit der CB750K DOHC mit je 4 Ventilen pro Zylinder, 68 PS und einer neuen Verkleidung heraus. Erneut wurde Honda Nummer Eins auf dem Markt. Im Juni 1979 folgte die CB750F, entwickelt aus der in Europa sehr populären CB900F, welche wiederum aus der Entwicklung der RCB-Rennmaschinen entstammte: Tiefliegender Lenker, hinten liegende Fußraster, welche eine Sitzhaltung erlaubten, die der eines Reiters ähnlich war. Ein Styling, welches den Standard für die 80-ziger Jahre setzte.

Die CB750F hat einen 4-Zylinder DOHC-Motor mit je 4 Ventilen und das Modell 1981 entwickelt 70 PS bei 748 ccm. Der Rahmen ist aus geschweißtem Rohr, Halb-Luft-Aufhängung vorne und FQV-Hinterradaufhängung, Doppelscheibenbremsen vorne und Einfach-Scheibenbremsen hinten. Das neu entworfene Schutzblech mit Spoiler wurde begeistert von den Fans aufgenommen, ebenso wie die fließenden Linien vom Tank bis zum Schlußlicht. Damit hat Honda eine Maschine, welche den Ansprüchen und Erfordernissen der kommenden Jahre entspricht.

READ BEFORE ASSEMBLY.
ERST LESEN — DANN BAUEN.



★ Study the instructions and photographs before commencing assembly.

★ You will need a sharp knife, a screwdriver, a file and a pair of pliers.

★ Do not break parts away from sprue, but cut off carefully with a pair of pliers.

★ Use cement sparingly. Use only enough to make a good bond.

★ Apply cement to both parts to be joined.

● This mark denotes the colour. Colour numbers in instructions are available in Tamiya Acrylic Paints.

★ Vor Beginn die Bauanleitung studieren und den Nummern nach die Elemente zusammenbauen.

★ Bauteile nicht vom Spritzling abbrechen, vorsichtig abschneiden oder abwickeln. Teile vor Kleben zusammenhalten, auf genauen Sitz achten. Nicht zuviel Klebstoff verwenden. Kleine Teile hält man mit Pinzette fest.

★ Abziehbilder vorsichtig von der Unterlage im Wasser abschieben, auf richtigen Sitz achten und gut trocknen lassen.

● Dieses Zeichen zeigt die Farbe und Farbnummer der Tamiya Acryl-Farben.

Do not break parts from sprue, but remove them carefully with a cutting tool.

Bauteile nicht vom Spritzling abbrechen vorsichtig abschneiden oder abwickeln.

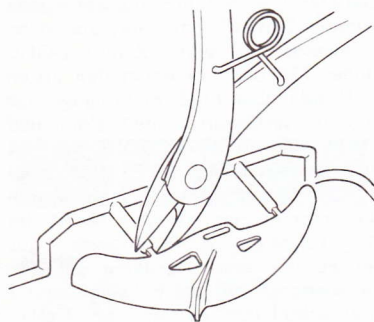

2 «Completed Engine»
 «Kompletter Motor»

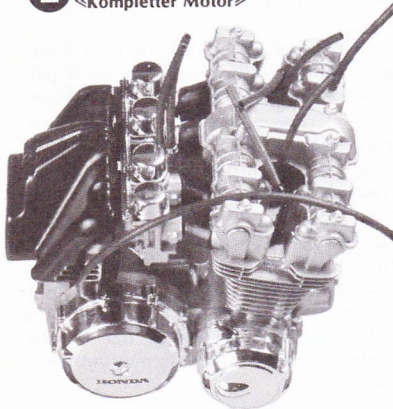

1 Assembly of Engine Parts
 Motorteile

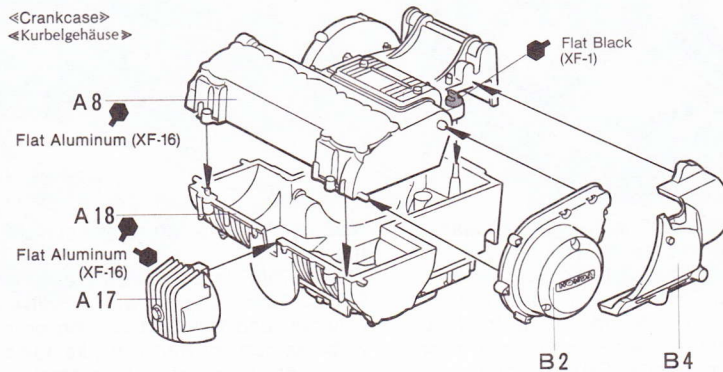
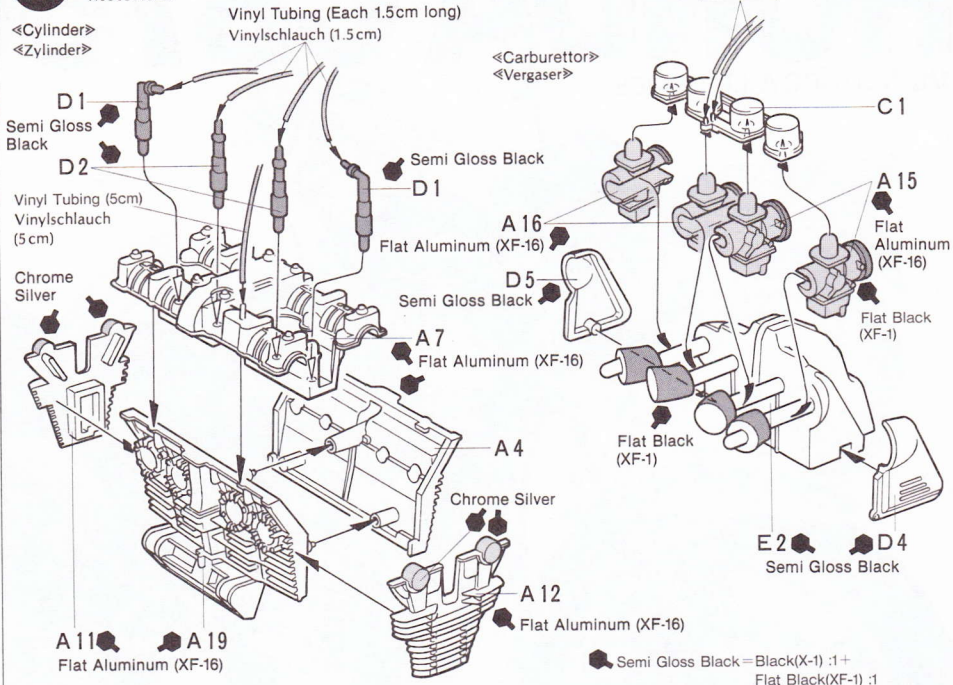

2 Completion of Engine
 Motorenbau

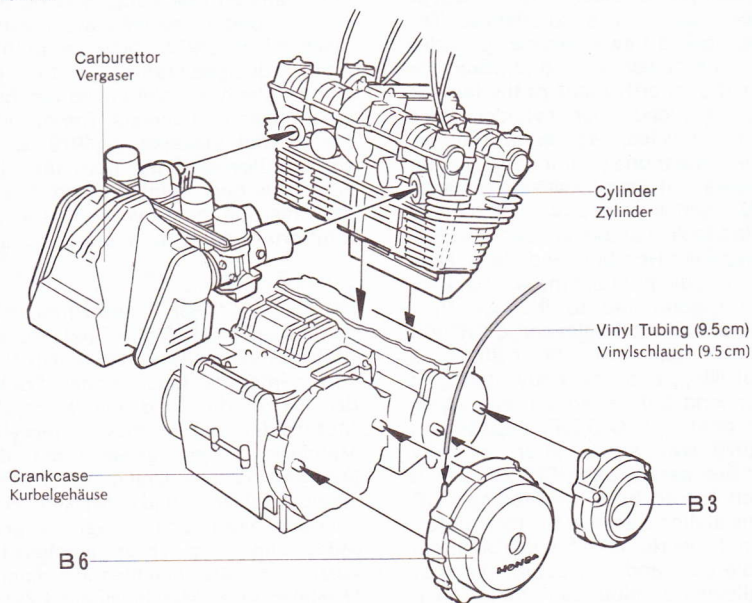

3 «Attached Engine»
«Eingebauter Motor»

Black areas shown below should be removed.

Cut off
Abschneiden

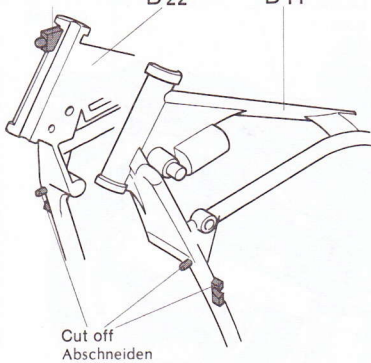

4 «Assembled Rear Wheel»
«Komplettes Hinterrad»



5 «Assembled Swing Arm»
«Komplette Radgabel»

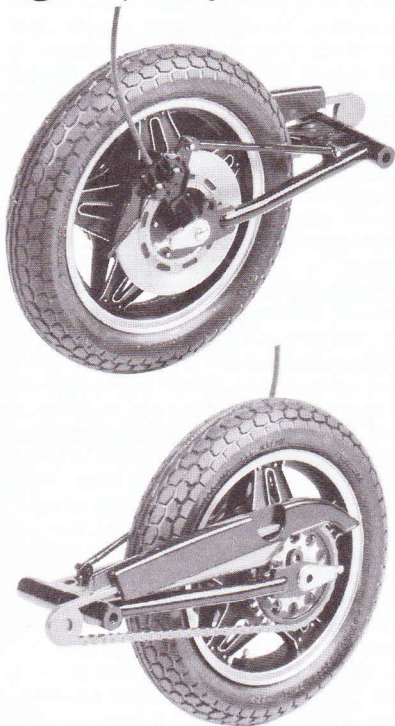

3 Engine Attachment
Einbau Motor in Rahmen

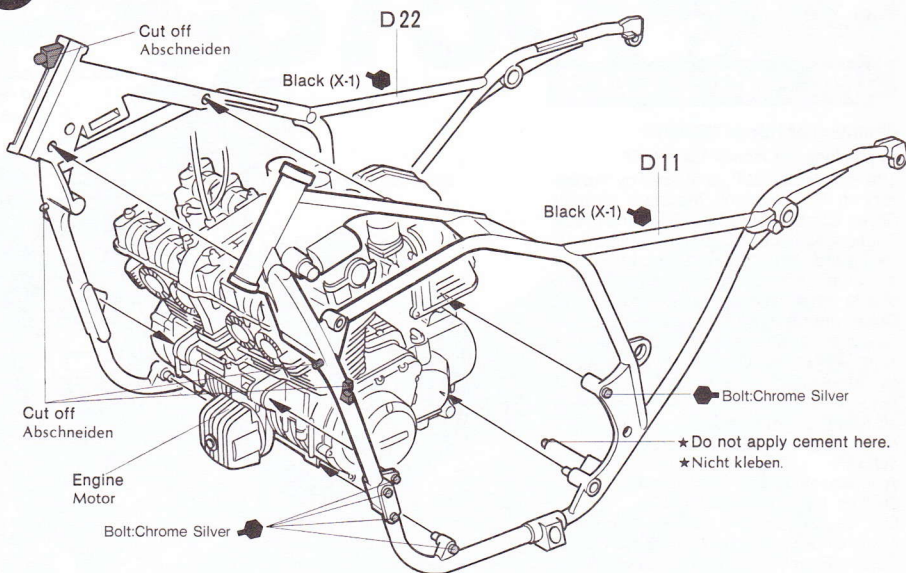

4 Assembly of Rear wheel
Hinterrad Montage

«Rear Wheel»
«Hinterrad»

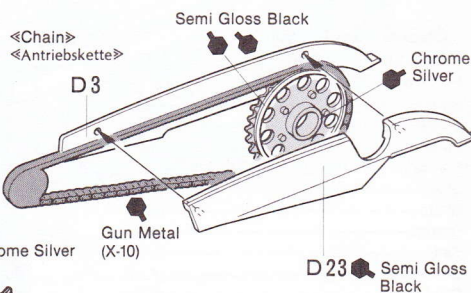
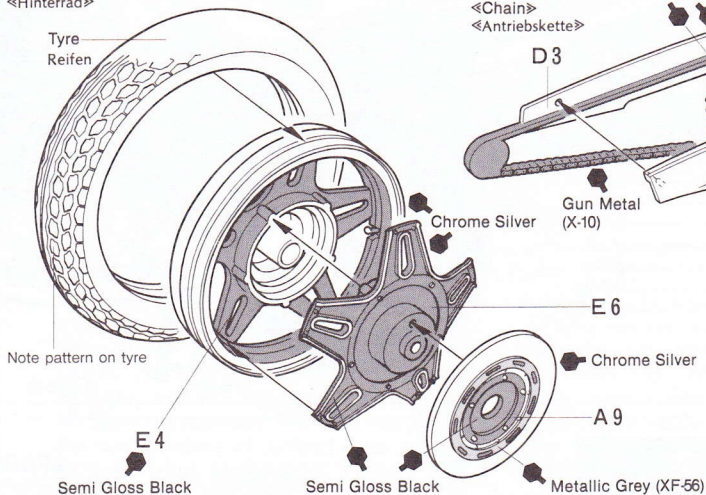

5 Assembly of Swing Arm
Radgabel Montage

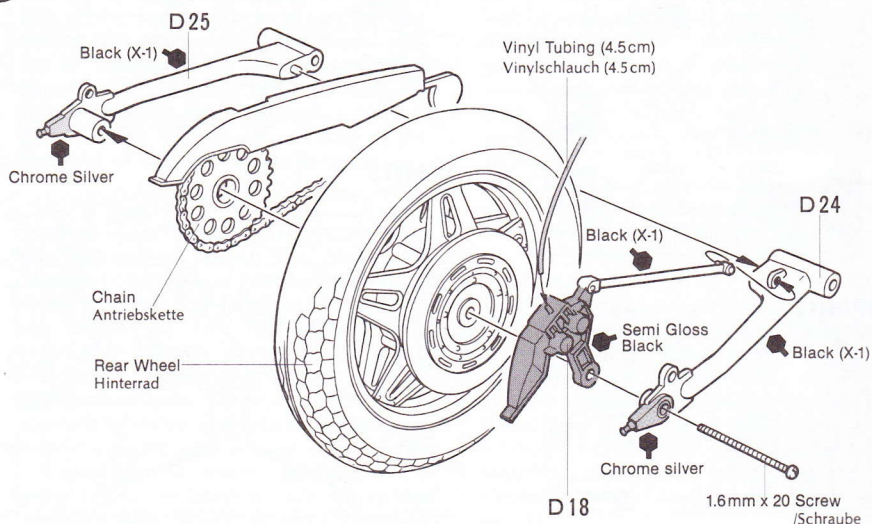

6 «Attached Swing Arm»
«Eingebautes Hinterrad»



Before cementing plated parts, remove plating with a knife etc. from the surface to which cement is applied.
Chrometeile: Vor dem Kleben muss an den Klebestellen die Chromschicht abgeschabt werden, da sonst Klebstoff nicht bindet.

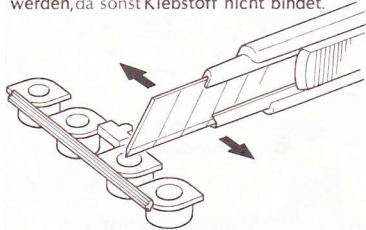

8 «Attached Mufflers»
«Ansicht von unten»

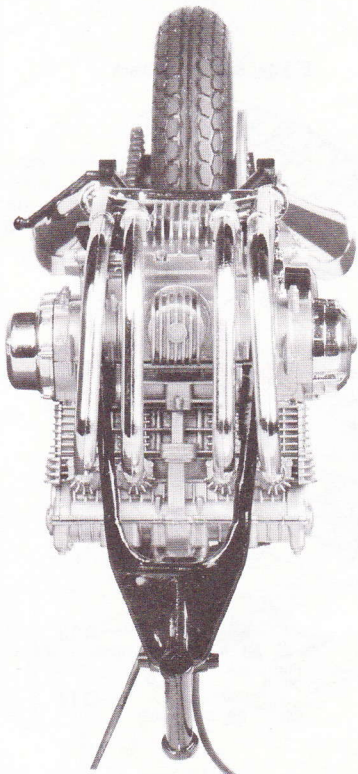

6 Attaching Swing Arm
Einbau der Hinterradgabel

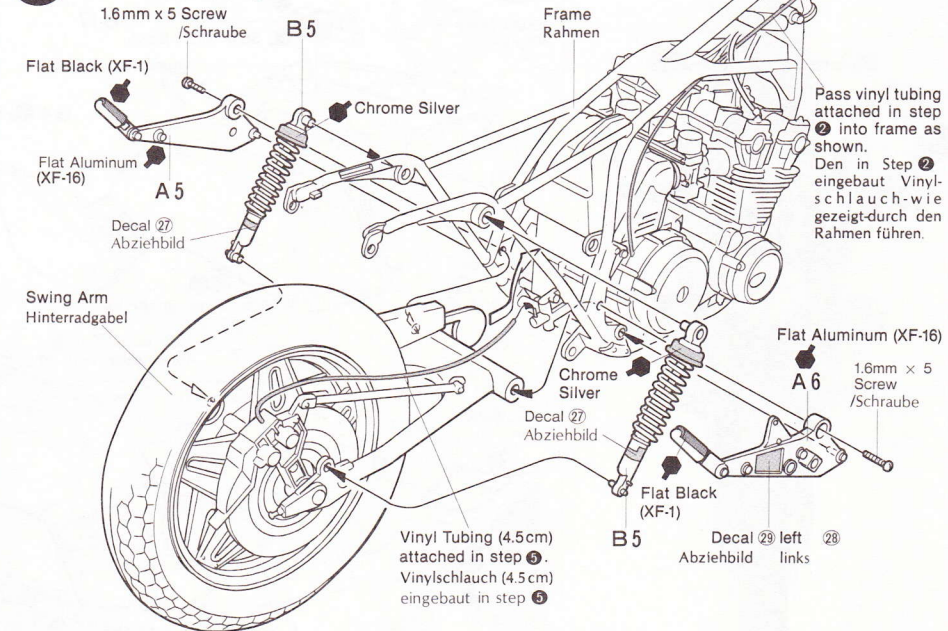

7 Assembly of Mufflers
Zusammenbau der Auspuffe

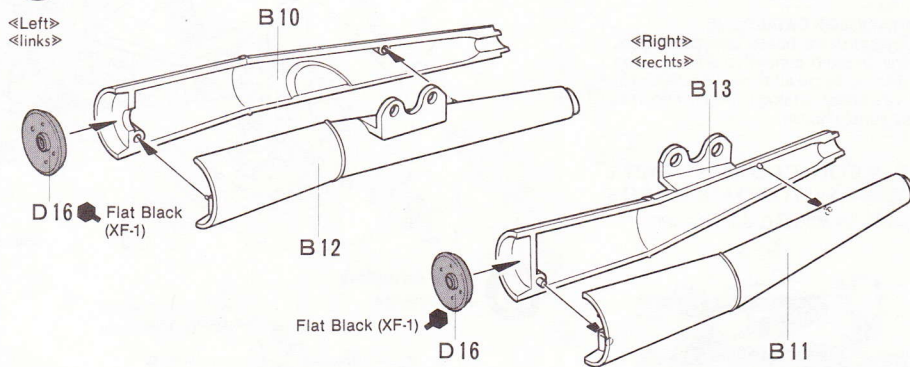

8 Attaching Mufflers
Einbau der Auspuffe

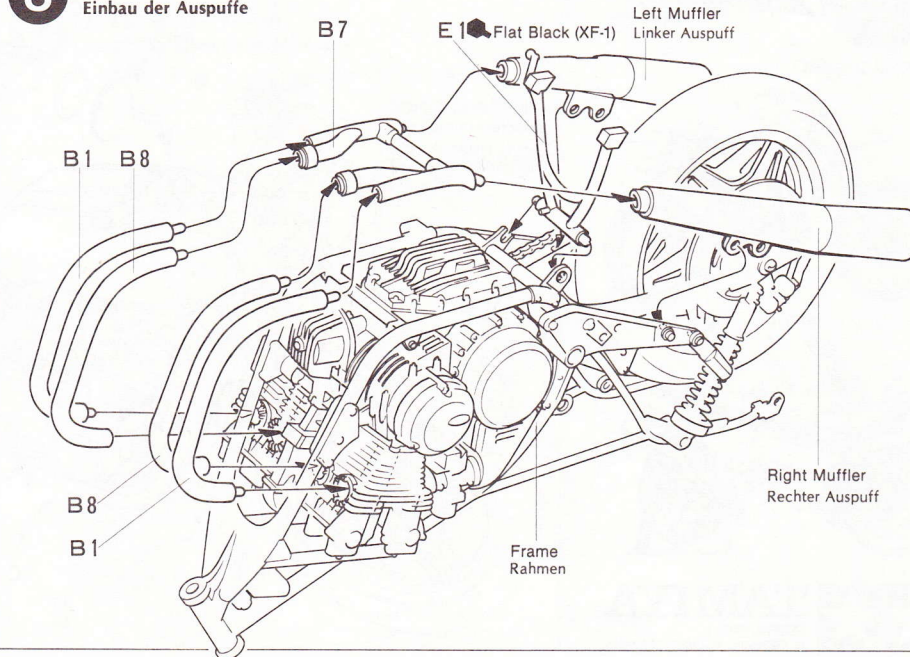

9 <<Assembly of Front Parts>>
<<Frontteile>>

<<Headlight>>
<<Scheinwerfer>>

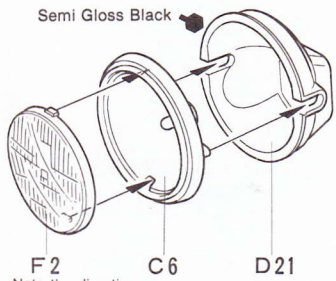

Note the direction

<<Meters>>
<<Tachometer>>

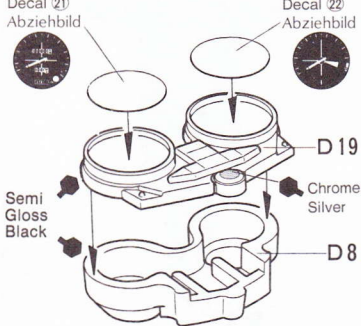

<<Painting of Meter Panel>>
<<Bemalung des Tachometers>>

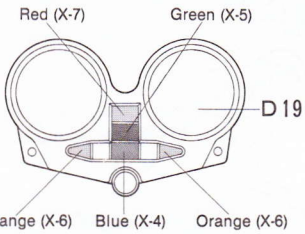

10 <<Completed Front Fork>>
<<Komplette Vorderrad-Gabel>>



9 Assembly of Front Wheel
Vorderrad Montage

<<Front Wheel>>
<<Vorderrad>>

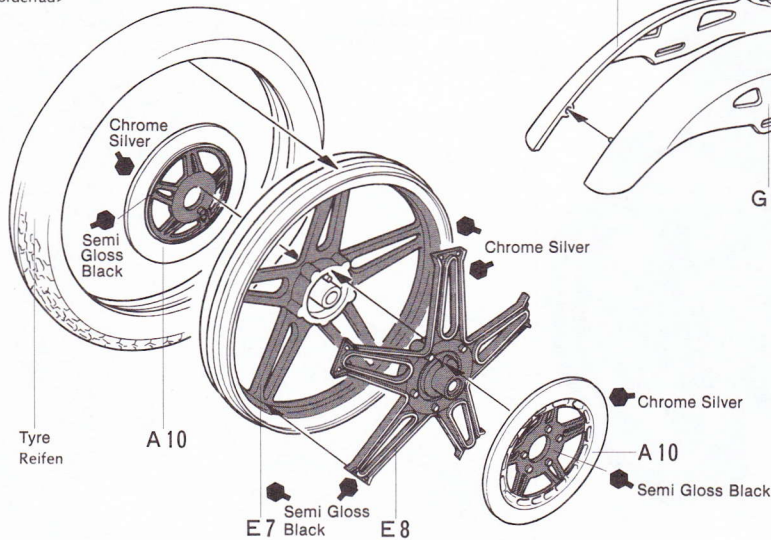

<<Front Fender>>
<<Vorderes Schutzblech>>

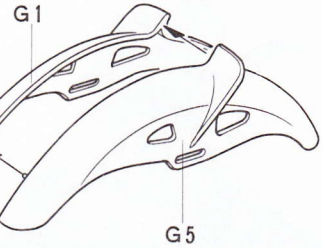

10 Assembly of Front Fork
Vorderrad-Gabel

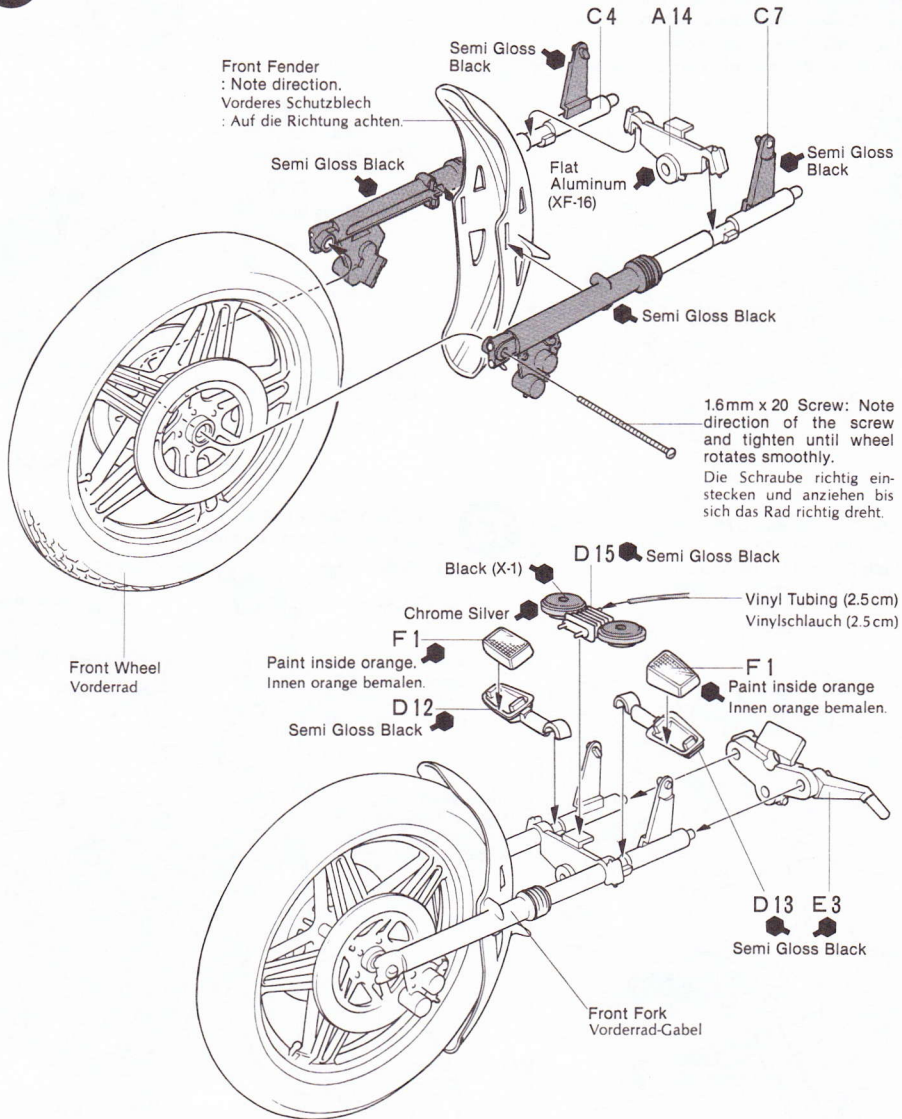

11 «Attached Front Fork»
«Eingebaute Vorderrad-Gabel»



11 Attaching Front Fork
Einbau der Vorderrad-Gabel

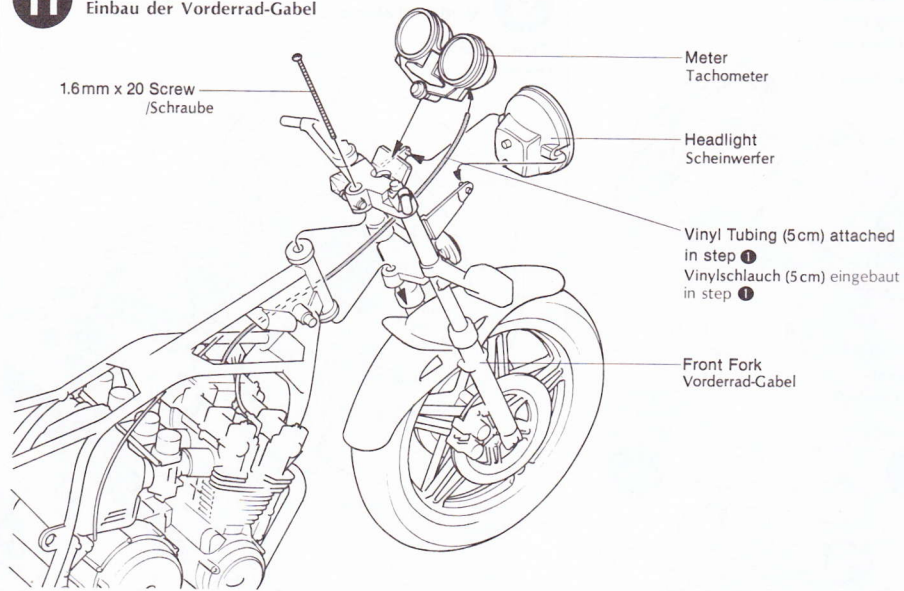

12 Assembly of Rear Fender
Vorderes Schutzblech

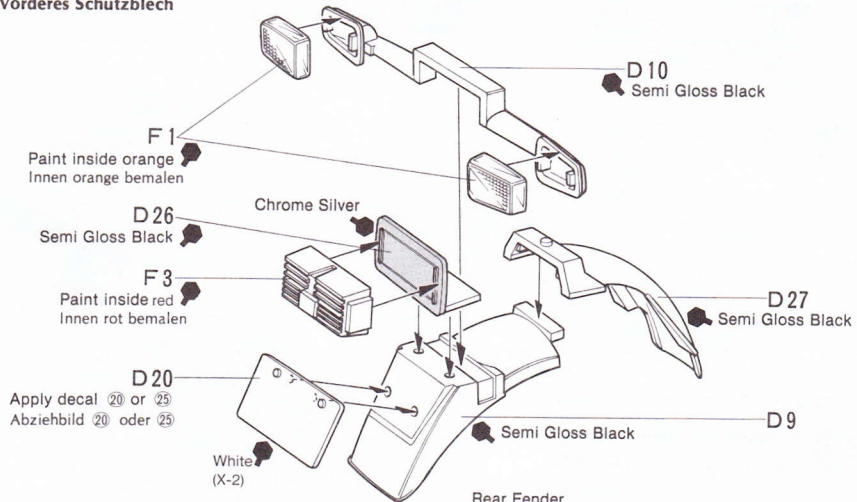

13 Attaching Rear Fender
Einbau des Hinteres Schutzblechs

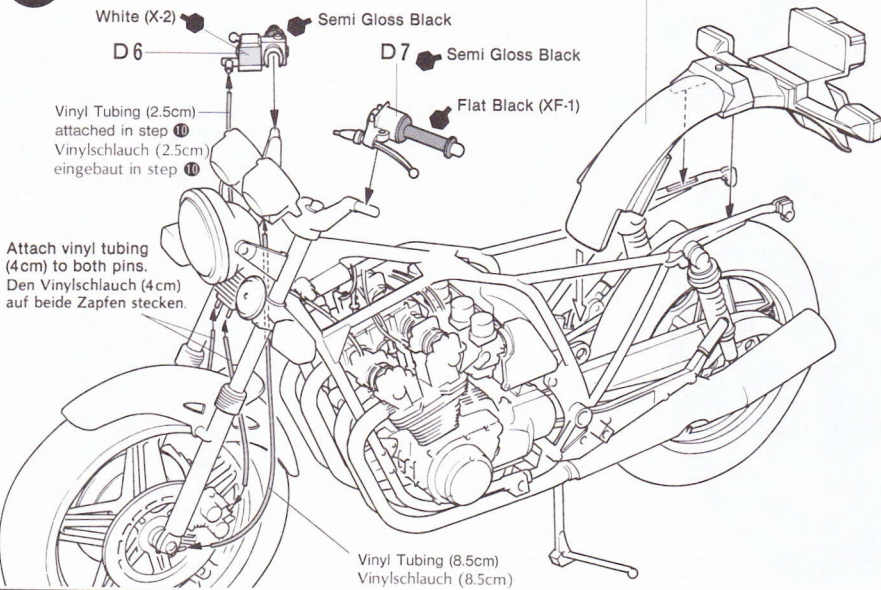

13 «How to attach Rear Fender»
«Einbau des Hinteres Schutzblechs»

Attach Rear Fender as shown.
Hinteres Schutzblech wie gezeigt einbauen.

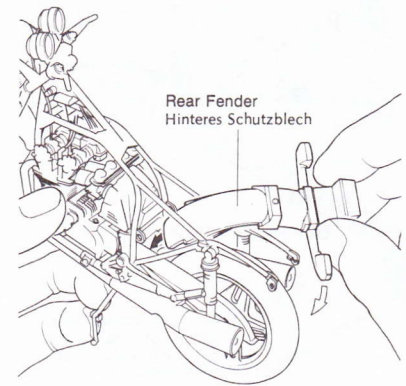

«Attaching D6 and D7»

«Einbau D6 und D7»
Attach D6 and D7 as shown.
D6 und D7 wie gezeigt einbauen.

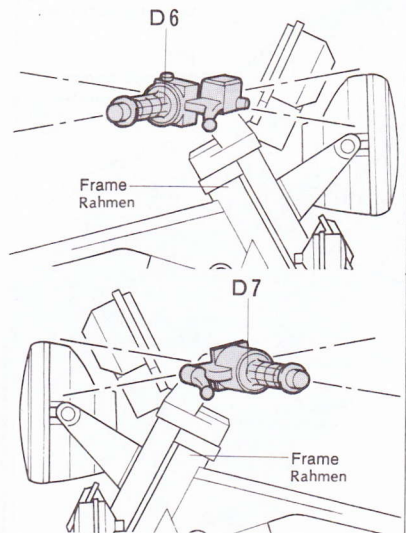

14 <<Completion>>
<<Endmontage>>



TAMIYA COLOR CATALOGUE
The latest in cars, boats, tanks and ships. Motorized, radio controlled and museum quality models are all shown in full color in Tamiya's latest catalogue. At your nearest hobby supply house.

BUILD A COLLECTION OF TAMIYA PRECISION MOTORCYCLE MODELS
1/12 YAMAHA YZR500 G.P. RACER

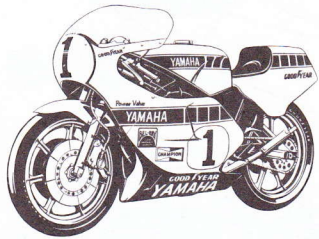

1/12 KTM 250 MX

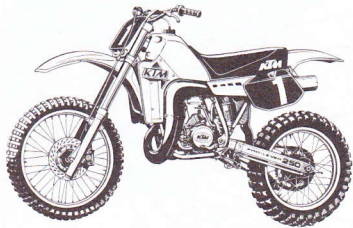

1/12 HONDA VFR750R

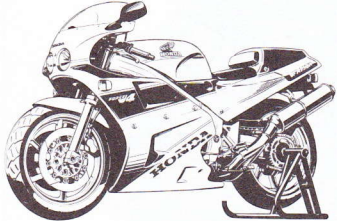

TAMIYA
TAMIYA, INC.
3-7, ONDWARA, SHIZUOKA-CITY, JAPAN.

14 Attaching Fuel Tank
Einbau des Tanks

<<Fuel Tank>>
<<Tank>>

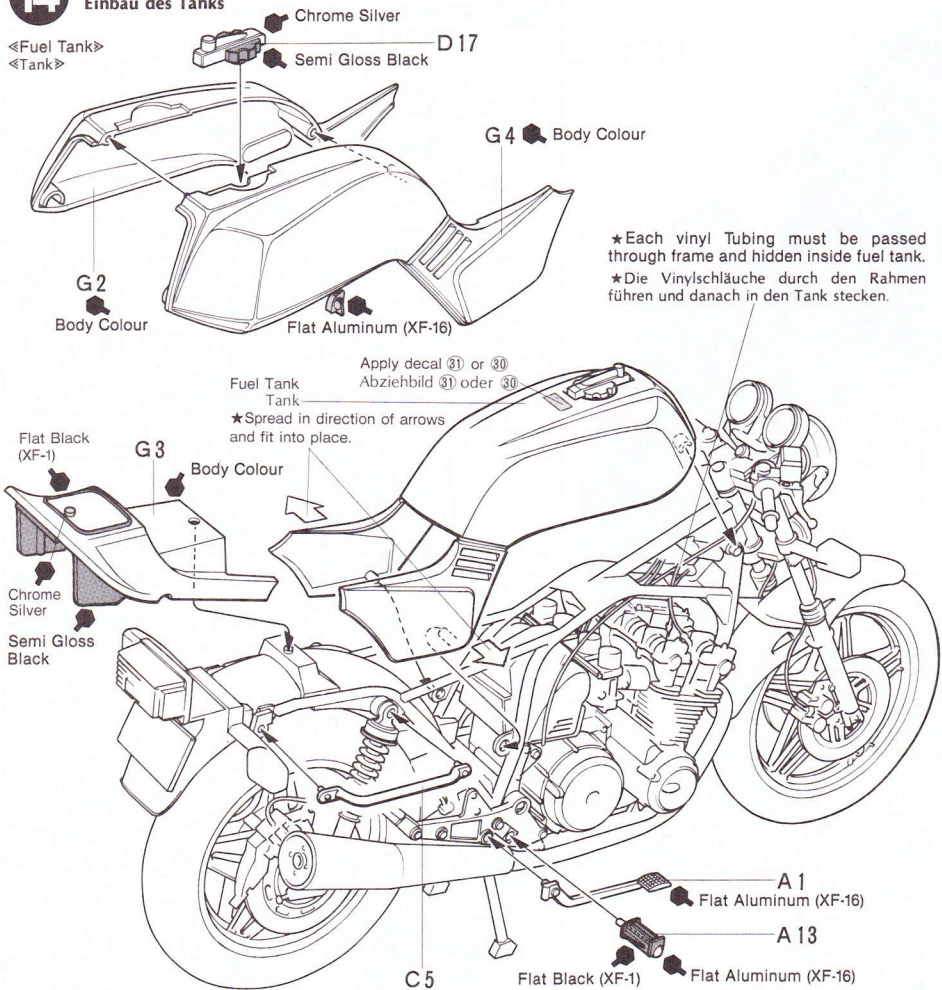

15 Final Assembly
Endmontage

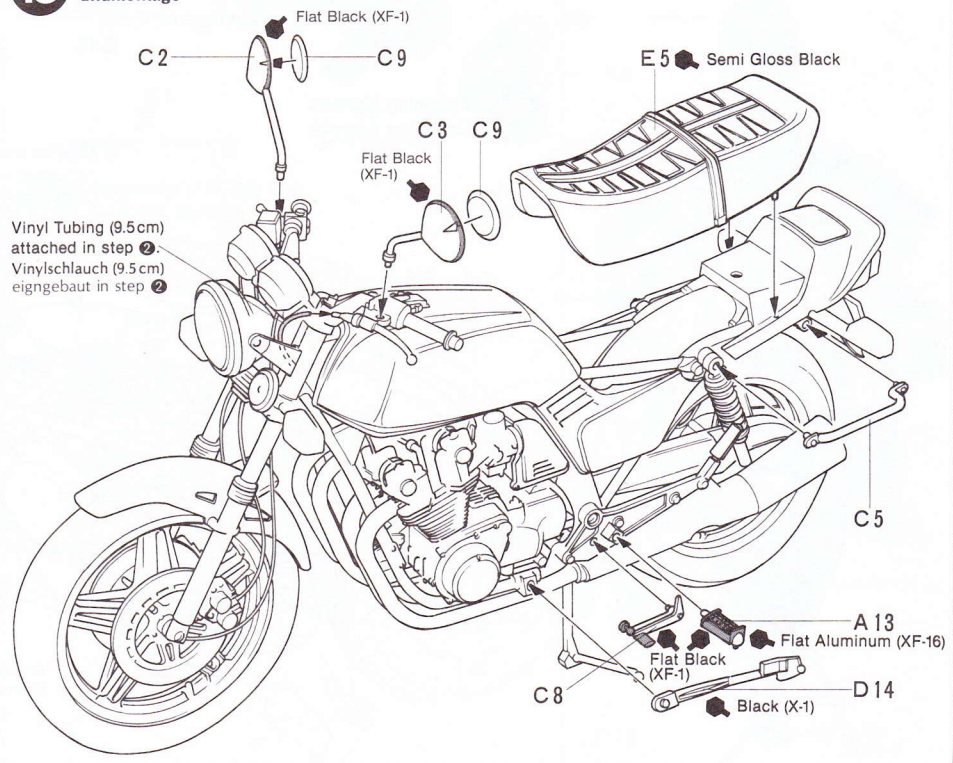

PAINTING



APPLYING DECALS

«Painting of Honda CB750F»

«Bemalung der Honda CB 750 F»

The Honda CB750F, is offered by the factory in three colors. Magnam Metallic Silver; Candy Bourgogne Red; and Black. These basic colors are enhanced with well matched colour striping of the shaded style. Kit includes decals of this shade striping for all basic body colors. Detail painting is shown during the construction and should be done at that time. Apply decals referring to the drawings at right.

Drei verschiedene Farb-Variationen stehen ab Fabrik zur Auswahl: Magnam-Metallic-Silber, Burgund-Rot und Schwarz.

Jede einzelne Farbe ist mit den passenden Streifen farblich abgestimmt.

Der Bausatz enthält die entsprechenden Abziehbilder und die Bemalung für die Details entnehmen Sie bitte den einzelnen Baustufen der Bauanleitung. Das Anbringen der Abziehbilder zeigt die Zeichnung rechts.

«Colours Required»

«Bemalungen benötigt»

(For body painting)

- Red.....(X-7)
- Black.....(X-1)
- Silver

(For detail painting)

- Black.....(X-1)
- White.....(X-2)
- Orange.....(X-6)
- Red.....(X-7)
- Gun Metal.....(X-10)
- Flat Black.....(XF-1)
- Flat Aluminum.....(XF-16)
- Metallic Grey.....(XF-53)

- Body Colour
- Silver
- Red (X-7)
- Black (X-1)

Striping varies according to the body colour. Apply decal ①-⑥ with silver body, ⑦-⑫ with red body and ⑬-⑱ with black body.

Die Streifen sind je nach Verkleidungs-Farbe verschieden zu wählen:
Abziehbild ① — ⑥ für silberne Verkleidung.
Abziehbild ⑦ — ⑫ für rote Verkleidung.
Abziehbild ⑬ — ⑱ für schwarze Verkleidung.

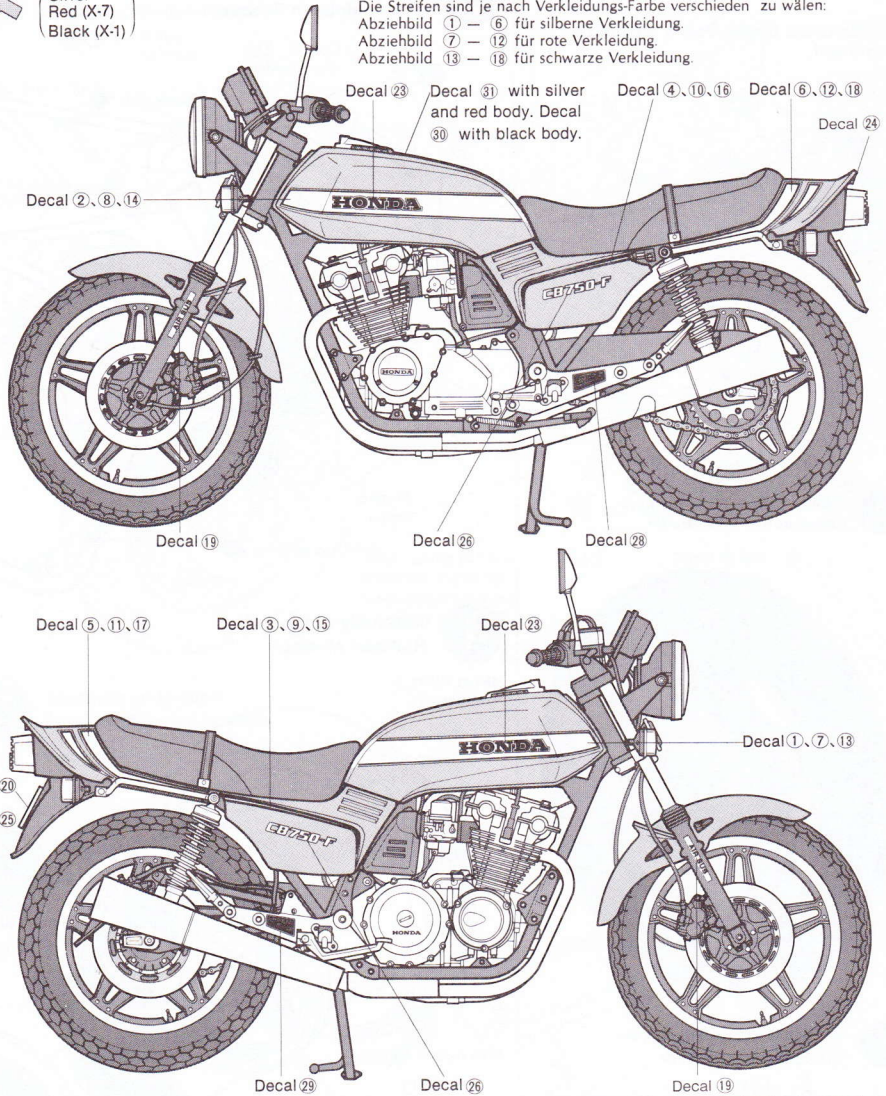

PARTS

APARTS

Parts 2 and 3 not used.

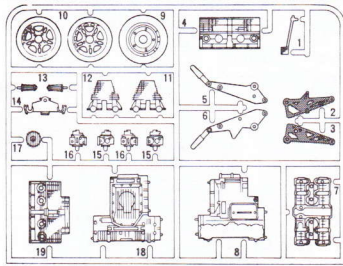

BPARTS

Part 9 not used.

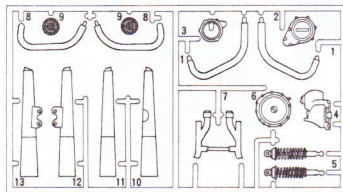

EPARTS

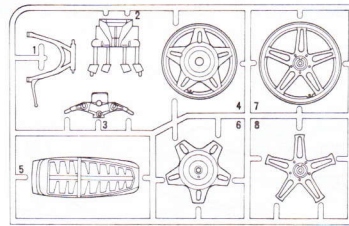

DPARTS

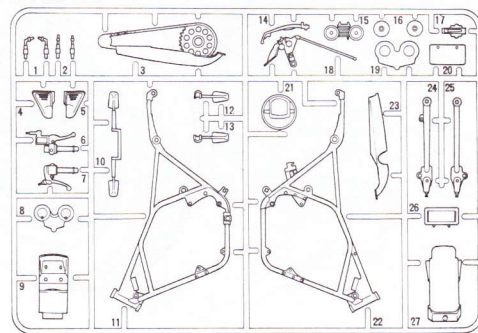

GPARTS

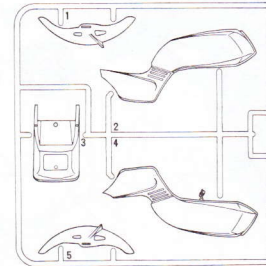

CPARTS

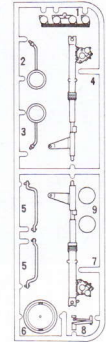

FPARTS

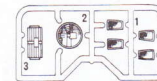

Decal

- «Metal Parts Bag»
- Front Tyre
- Rear Tyre
- 1.6mm x 20 Screw
- 1.6mm x 5 Screw
- Vinyl Tubing (50cm)