

# YAMAHA XV1000



## Virago



### 1/12 MOTORCYCLE SERIES

This kit was designed with the full cooperation of the Yamaha Motor Co., Ltd.  
Dieser Kit wurden in Zusammenarbeit mit der Yamaha Motor Co., Ltd. entworfen.

The motorcycle, along with the automobile, has played a big role in transporting humans from place to place for many years. Man has always been able to adapt his tools for specific needs, and as the motorcycle became more and more a sport, or leisure transportation vehicle, it has been designed for more specific purposes. The off road, touring, motocross and speed bikes as well as the basic transportation motorcycle can be seen in most countries, but America seems to have a certain styling all its own. This so called "Chopper style" came about during the mid 1960's from the many modified Harley's done by members of the many motorcycle clubs around the country. There are many long straight stretches of good, high speed roadways in America, and to sit back comfortably, with feet resting on forward pedals, brought about these modifications. The Yamaha Company of Japan is well known for quality bikes around the world, and they have been making bikes for specific areas for years. The Yamaha XS650 Special released in 1978 had the American look, and since then this company has marketed bikes with similar styling. The XV1000 Virago is their latest, large bore, American styled motorcycle and sure to become popular. Its front wheel caster angle of 32 degrees provides an extended wheel base of 1525mm, making its straight run-

ing ability superb. The wide, pull back type of handle bars and the forward placed foot rests, allow the rider to sit up as if he was on a horse. A separate looking, loose cushion seat is almost like sitting on a sofa, and it is positioned at a height of only 715mm. The 70hp 981cc twin cylinder is in the "V" format and transmits its power via an enclosed drive shaft for quiet, maintenance free operation. The bike comes with much chrome and lots of gold plating, but it is done in such a manner that the bike does not look gaudy. It is a luxurious and comfortable riding motorcycle, designed for the American bike enthusiast, but sure to be well received throughout the globe. The Virago seems to have the custom made finish and individual 60's styling that characterizes the true "Chopper" of America.

\* \* \*

Zusammen mit dem Automobil spielte das Motorrad für viele Jahre eine grosse Rolle im Transport von Menschen. Schon immer war die Menschheit in der Lage, seine Gebrauchsgegenstände, dem speziellen Zweck anzupassen. Als das Motorradfahren im Laufe der Zeit zu einem Hobby und Freizeitsport wurde, blieb die Weiterentwicklung natürlich nicht aus. In vielen Ländern sieht man heute das Motorrad auch im Rennen beim Off-Road, Touring, Moto-Cross und

Langstreckenrennen. In Amerika aber, scheint das Motorrad ein anderes Design zu haben, den Chopper Style. Diese Chopper kamen so um die Mitte der 60er Jahre auf die Strassen, es waren umgebaute Harley's, selbst umgebaut von den Motorrad-Fan's aus den vielen Motorrad-Club's im Lande. In Amerika gibt es sehr lange und gerade Strecken auf den Highway's und so war ein solcher Chopper schon ein bequemes Fahrzeug. Man sitzt zurückgelehnt auf dem bequemen Sattel und hat die Füssen auf den weit vorne liegenden Fussrastern.

Die Yamaha Company ist auf der ganzen Welt bekannt für Motorräder guter Qualität. Seit Jahren werden auch Motorräder gebaut, nach ganz speziellen Wünschen und als 1978 die XS650 herauskam, hatte diese schon den Amerika Look. Die XV1000 Virago ist das neueste Motorrad von Yamaha mit grossem Hubraum. Das Vorderrad steht im Winkel von 32 Grad und bringt dem Fahrzeug einen Radstand von 1525mm, hat somit eine hervorragende Strassenlage auf der Geraden. Der Lenker ist weit zurückgezogen und auf der hinteren Satteldecke sitzt man wie auf Oma's Sofa. Der Motor mit 981cc bringt 70 PS, hat zwei Zylinder im V-Format und bringt seine Kraft mit einer Welle auf das Hinterrad. Trotz viel Chrome und goldfarbenen Teilen sieht das Motorrad gut aus. Es ist ein luxuriöses, äusserst bequemes Motorrad nicht nur für die Ami-Fan's, sondern findet auch auf der ganzen Welt Begeisterung. Die VIRAGO dürfte wohl "der Chopper" von Amerika sein.

**READ BEFORE ASSEMBLY.**

**ERST LESEN — DANN BAUEN.**

- ★ Study the instructions and photographs before commencing assembly.
- ★ You will need a sharp knife, a screwdriver, a file and a pair of pliers.
- ★ Use cement sparingly. Use only enough to make a good bond.
- ★ Apply cement to both parts to be joined.

★ Make sure to ventilate room, when you use cement and paints.

● This mark denotes paint color, with color names and numbers for Tamiya Acrylic Paints and Tamiya Paint Markers. Page 8 has detailed painting instructions; however, some parts should be painted prior to model's completion, and these are called out during assembly.

★ Vor Beginn die Bauanleitung studieren und den Nummern nach die Elemente zusammenbauen.

★ Bauteile nicht vom Spritzling abbrechen, vorsichtig abschneiden oder abwickeln.

★ Teile vor Kleben zusammenhalten, auf genauen Sitz achten. Nicht zuviel Klebstoff verwenden. Kleine Teile hält man mit Pinzette fest.

★ Abziehbilder vorsichtig von der Unterlage im Wasser abschieben, auf richtigen Sitz achten und gut trocknen lassen.

★ Der Bastelraum sollte bei Verwendung von Farben und Klebstoff gut gelüftet sein.

● Dieses Zeichen zeigt die Farbe und Farbnummer der Tamiya Acryl-Farben und Paint Marker.

**CUTTING OFF PARTS  
ABSCHNEIDEN EINZELNER TEILE**

Do not break parts away from sprue, but remove them carefully with a cutting tool.

Bauteile nicht vom Spritzling abbrechen vorsichtig abschneiden oder abwickeln.

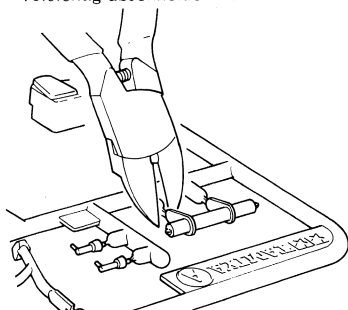

★ Before cementing plated parts, remove plating with a knife etc. from the surface to which cement is applied.

★ Chrometeile: Vor dem Kleben muss an den Klebestellen die Chromschicht abgeschabt werden, da sonst Klebstoff nicht bindet.

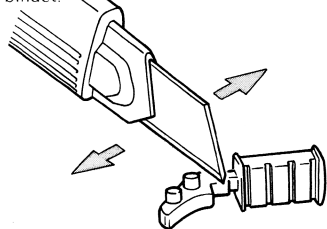

**1 ASSEMBLY OF FRAME  
MONTAGE DES RAHMENS**

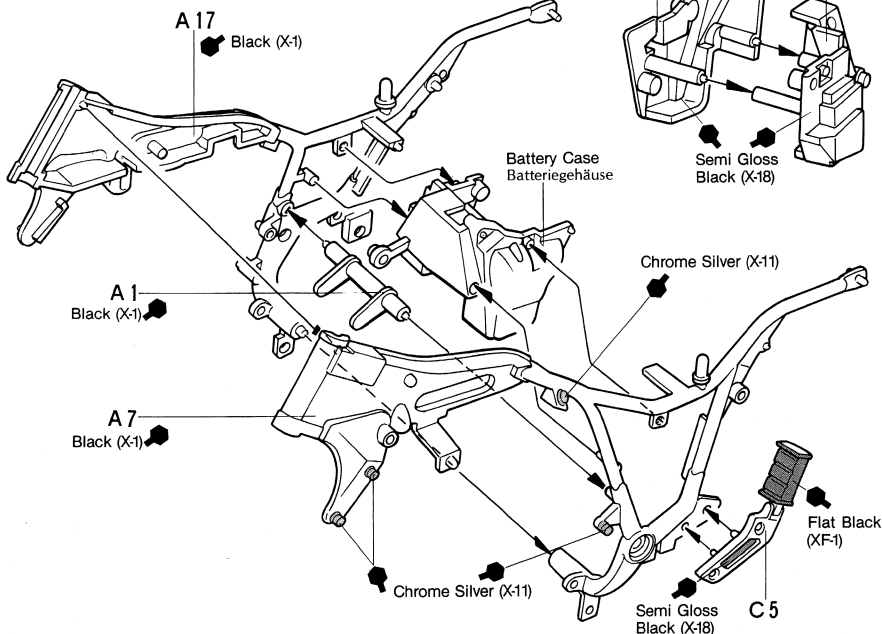

**2 REAR FENDER  
HINTERES SCHUTZBLECH**

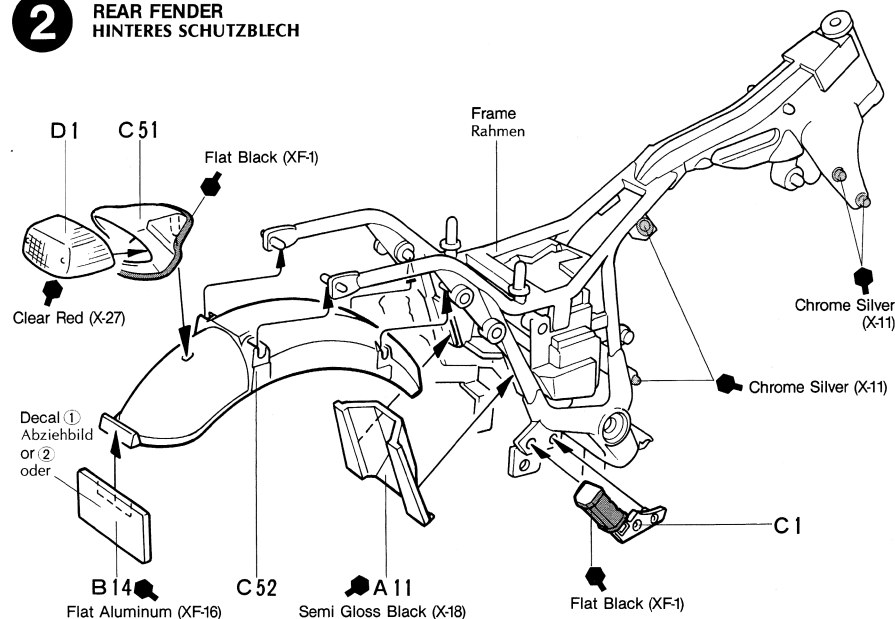

**3 CYLINDER HEAD  
ZYLINDERKOPF**

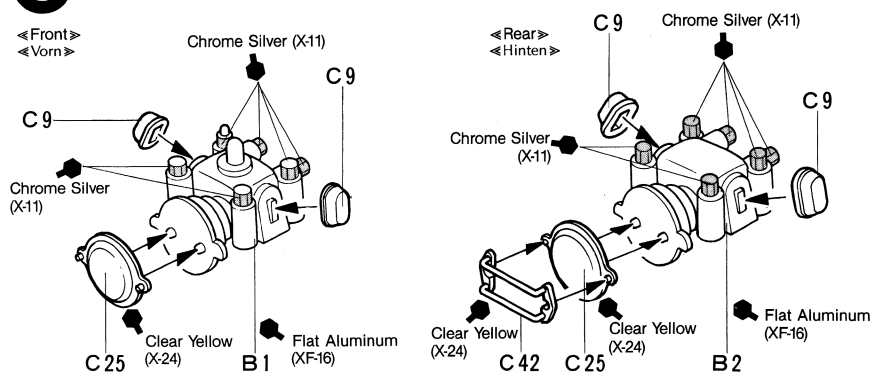

## 5 PAINTING OF CRANKCASE BEMALUNG DES KURBELGEHÄUSES

«Left»  
«Links»

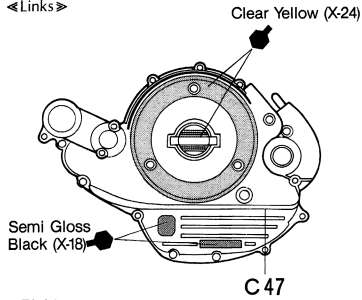

«Right»  
«Rechts»

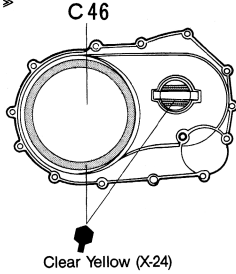

## 6 CARBURETOR VERGASER

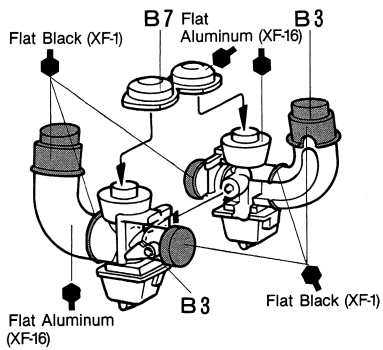

### ATTACHING PLUG WIRES ZÜNDKERZENKABEL

Secure wires A & B attached at step 4 as shown below.  
Die Zündkerzenkabel (siehe Step 4) jetzt wie unten gezeigt, anbringen.

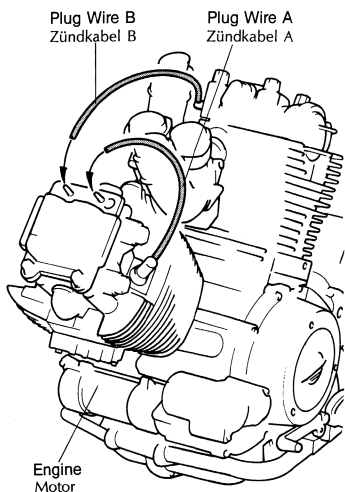

## 4 CYLINDER ZYLINDER

«Front»  
«Vorn»

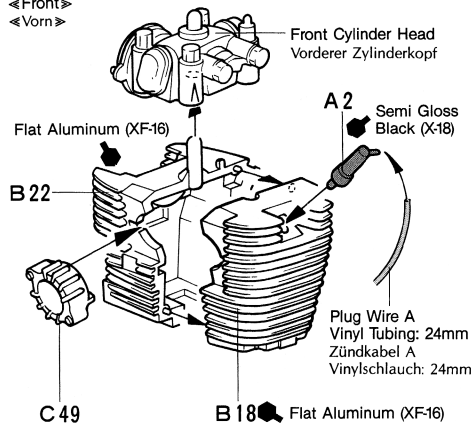

Rear Cylinder Head  
Hinterer Zylinderkopf

«Rear»  
«Hinten»

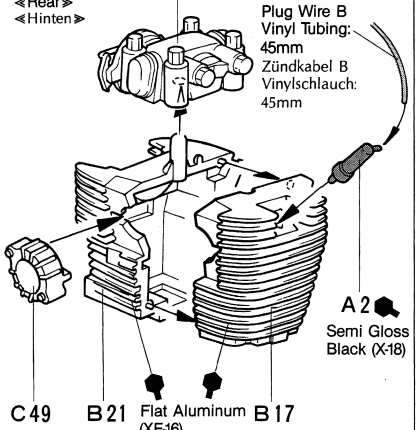

## 5 CRANKCASE KURBELGEHÄUSE

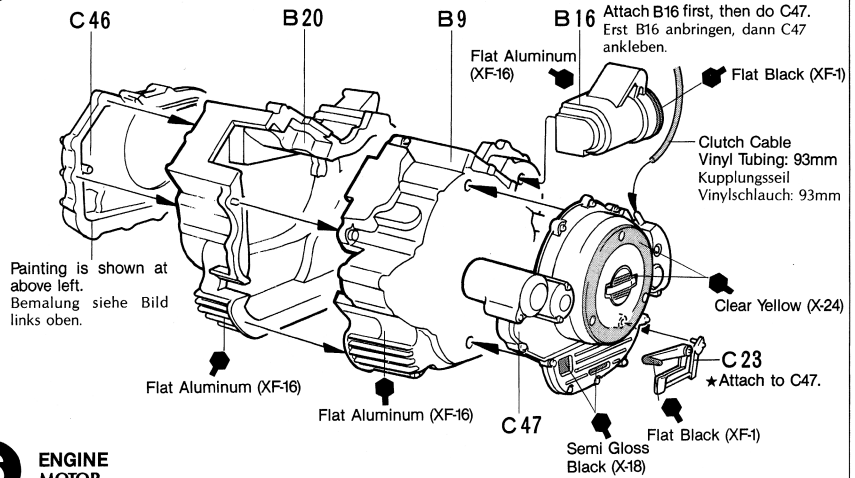

## 6 ENGINE MOTOR

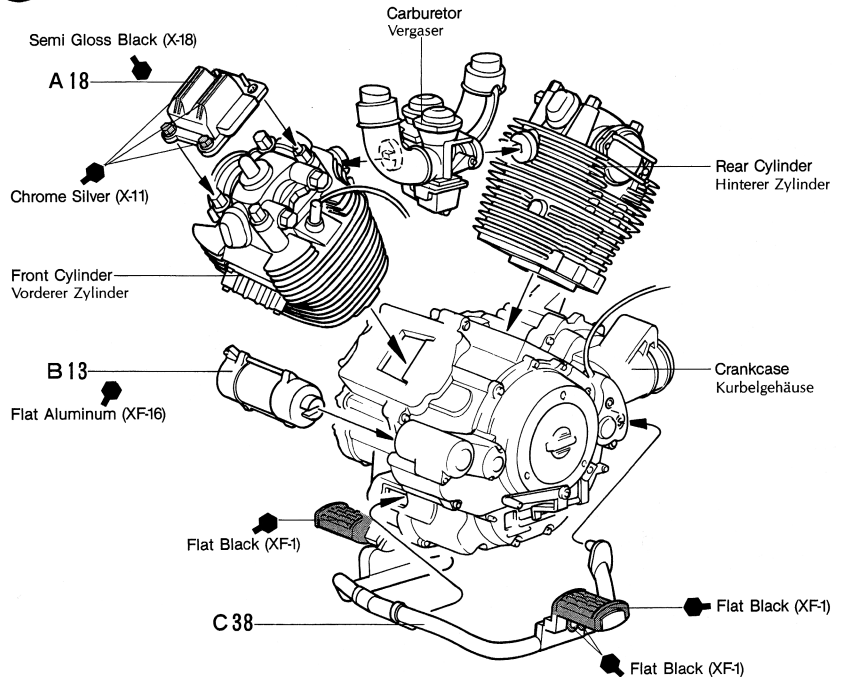

## 7 REAR WHEEL HINTERRAD

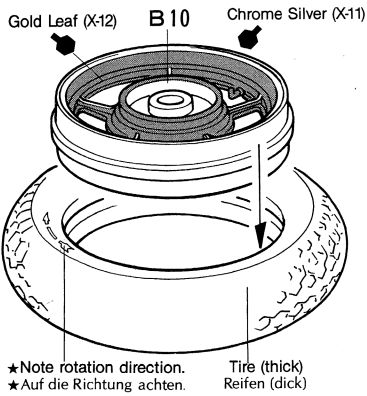

## 8 RIGHT SHOCK ABSORBER RECHTER STOSSDÄMPFER

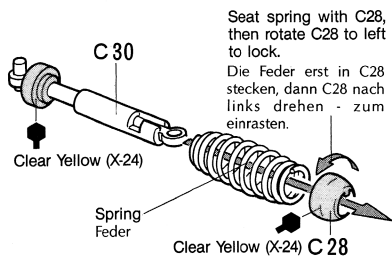

## 9 LEFT SHOCK ABSORBER LINKER STOSSDÄMPFER

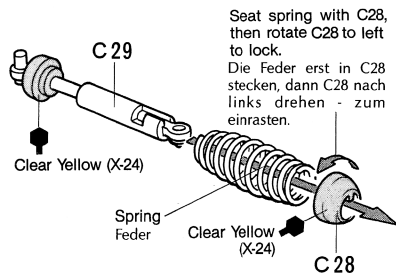

# TAMIYA MODEL MAGAZINE INTERNATIONAL

A magazine for enthusiasts who make or modify models of all kinds. From the neophyte to the expert, articles of interest about modeling and the full sized vehicle. Coverage of all plastic kit maker's products.



### TAMIYA ACRYLIC PAINTS

Need precise color matching? Try the new Tamiya acrylic paints. Engineered by modelers for modeler's use. The final cover for the finest models. Insist on Tamiya for perfect results.

### PAINT MARKER

Hand held, Tamiya enamel paint markers. For the final detail touch, and professional results. 12 of the most popular colors used in modeling. See and test them at your local hobby supply house.

## 7 ASSEMBLY OF SWING ARM MONTAGE DER HINTERRADGABEL

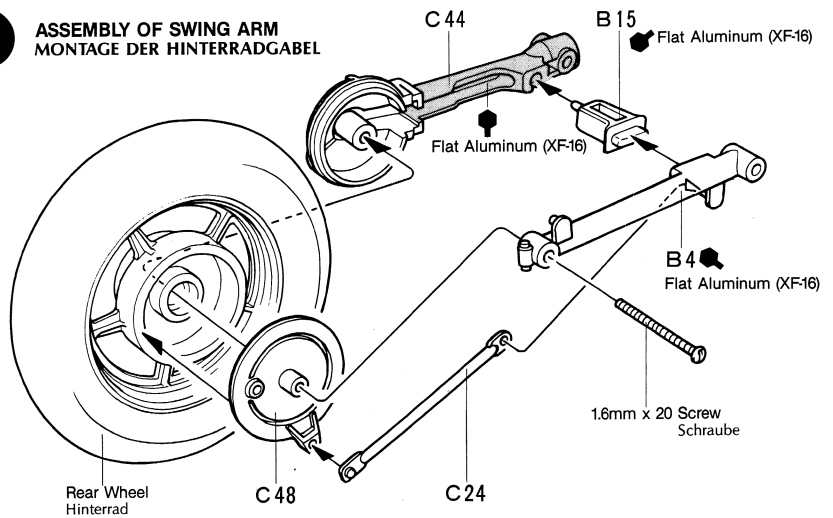

## 8 ATTACHING SWING ARM EINBAU DER HINTERRADGABEL

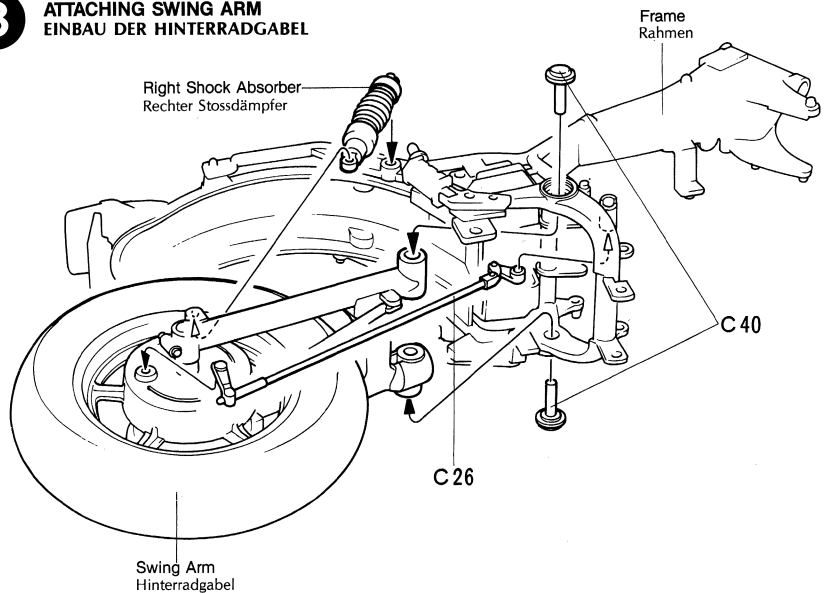

## 9 ATTACHING ENGINE EINBAU MOTOR IN RAHMEN

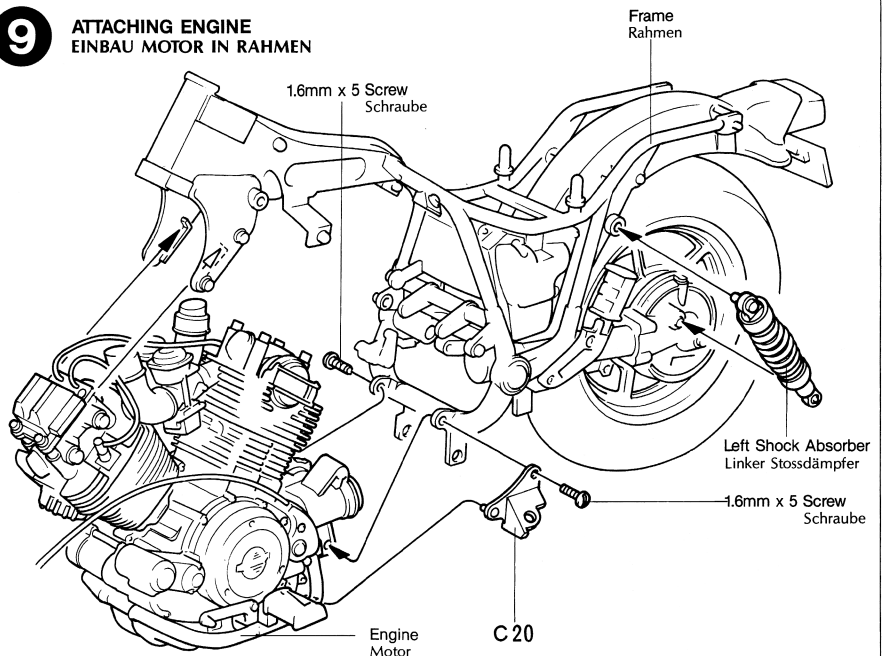



**10** MUFFLER AUSPUFF

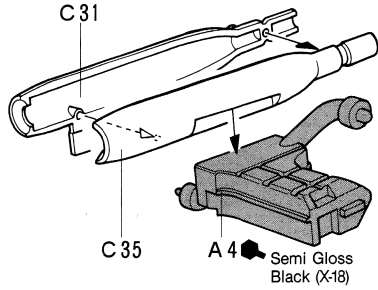

**11** MUFFLER AUSPUFF

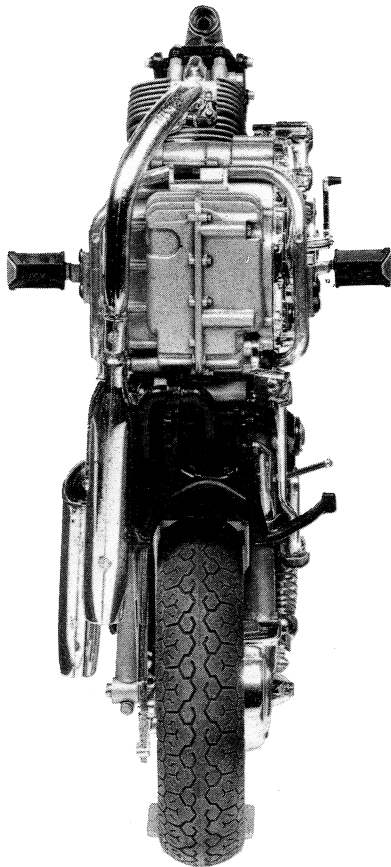
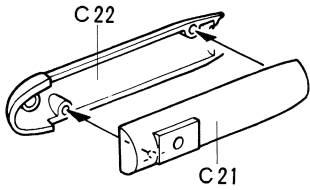

**10** ATTACHING MUFFLER EINBAU DER AUSPUFFROHRE

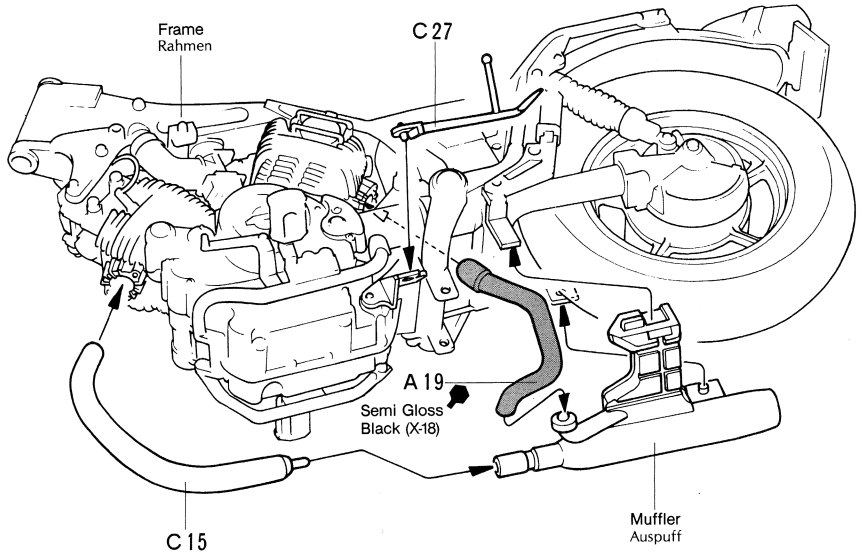

**11** ATTACHING MAIN STAND STÄNDER

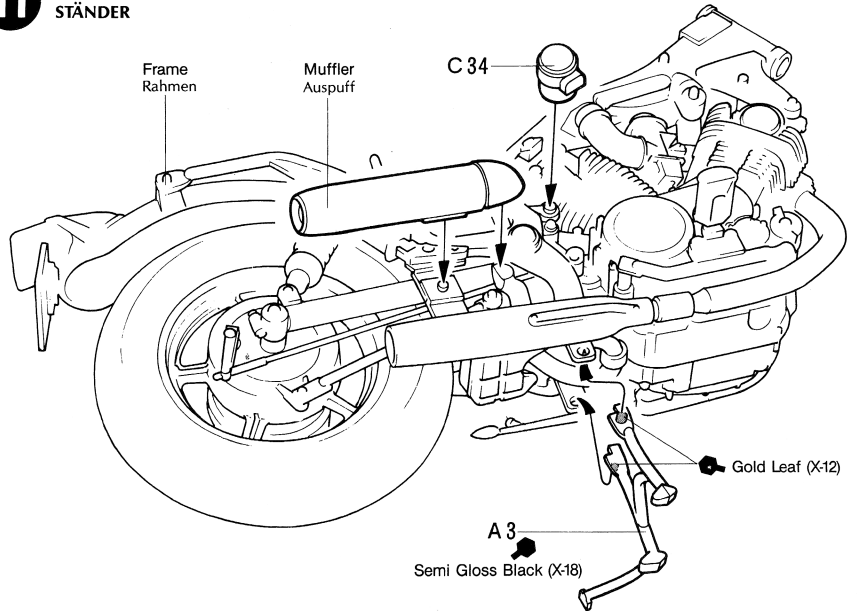

**12** FUEL TANK AND ELECTRICAL EQUIPMENT COVER TANK UND ELEKTRO-AUSRÜSTUNG-DECKEL

«Fuel Tank»  
«Tank»

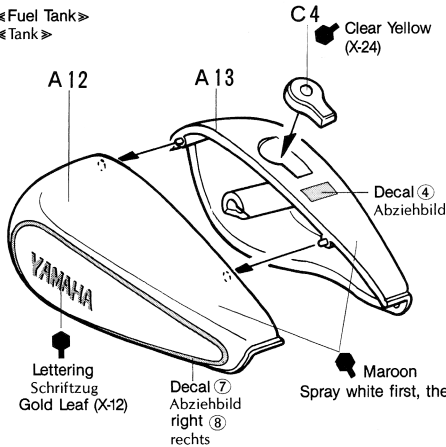

«Electrical Equipment Cover»  
«Elektro-Ausrüstung-Deckel»

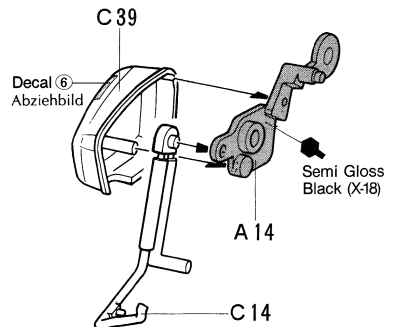

**TAMIYA COLOR CATALOGUE**  
The latest in cars, boats, tanks and ships. Motorized, radio controlled and museum quality models are all shown in full color in Tamiya's latest catalogue. At your nearest hobby supply house.

**13 ELECTRICAL EQUIPMENT COVER  
ELEKTRO-AUSRÜSTUNG-DECKEL**

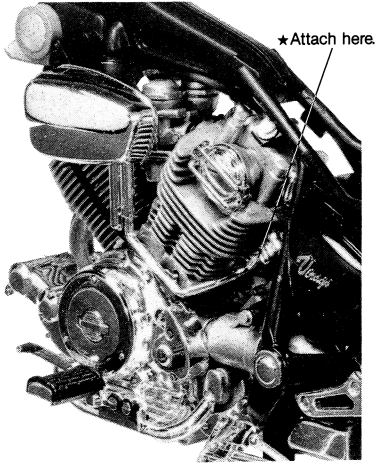

**BACK REST PAD  
RÜCKLEHNE**

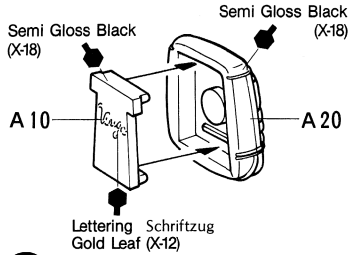

**14 FRONT FENDER  
VORDERES SCHUTZBLECH**

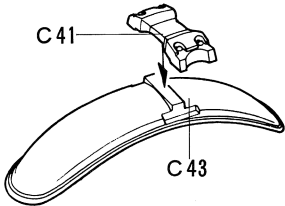

**REAR WHEEL  
HINTERRAD**

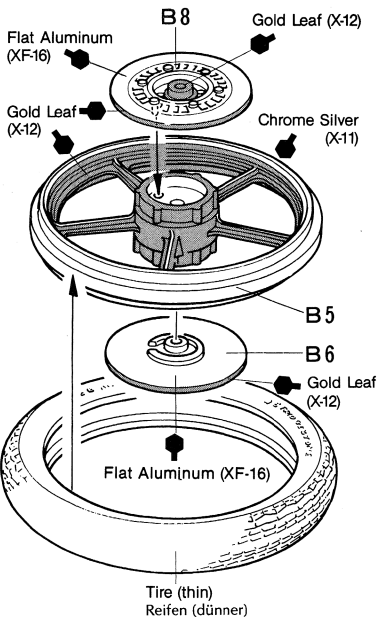

**13 ATTACHING BACK REST  
EINBAU DES SATTEL-GESTÄNGE**

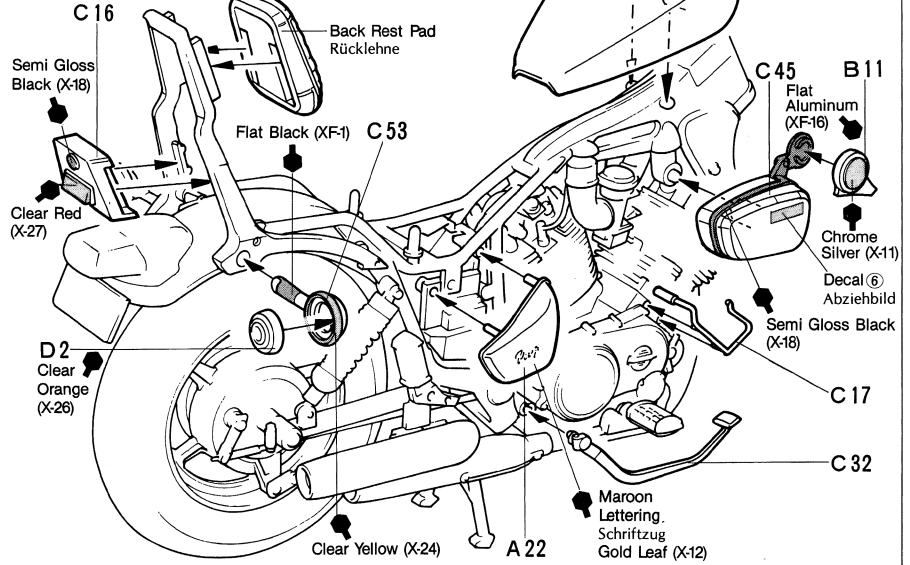
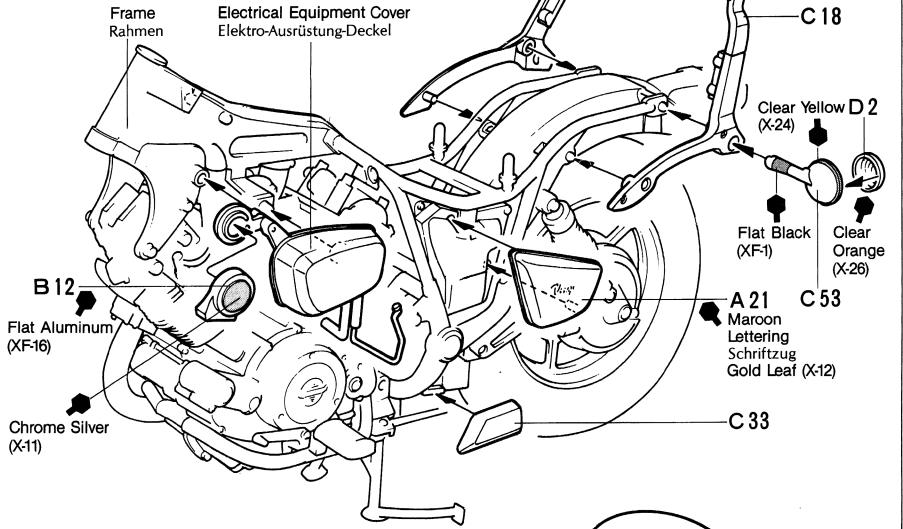

**14 FRONT FORK  
VORDERRADGABEL**

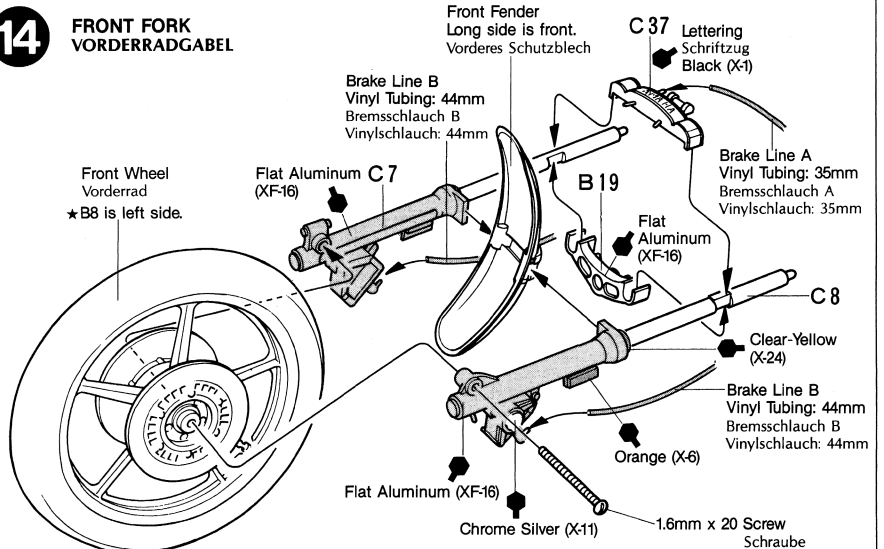

**15 HEADLIGHT SCHEINWERFER**

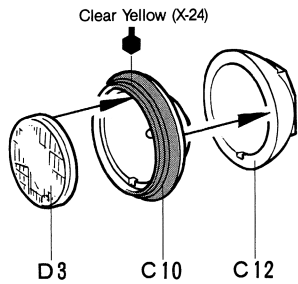

**15 HEADLIGHT AND METER SCHEINWERFER UND MESSER**

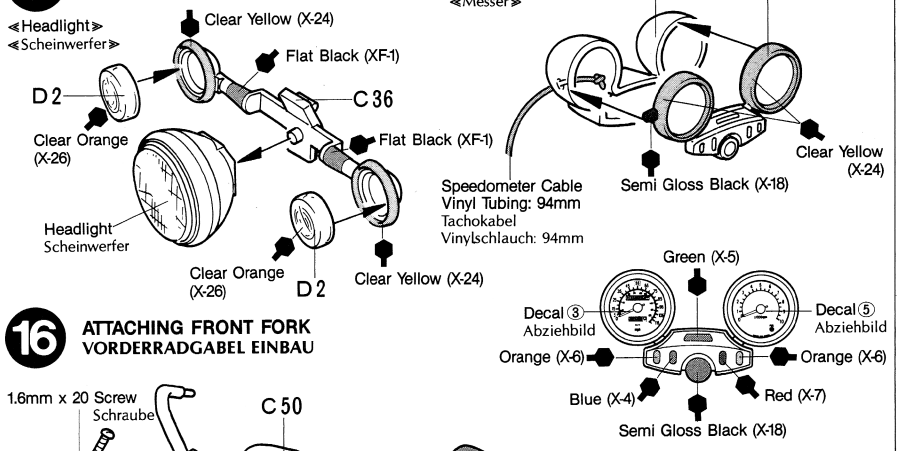

**16 ATTACHING FRONT FORK VORDERRADGABEL EINBAU**

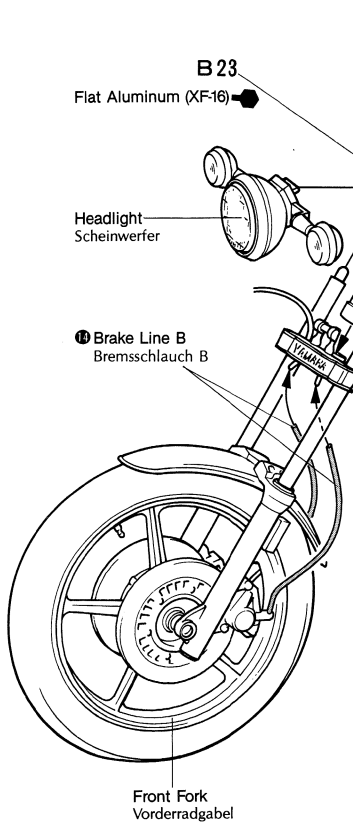

**16 ATTACHING FRONT FORK VORDERRADGABEL EINBAU**

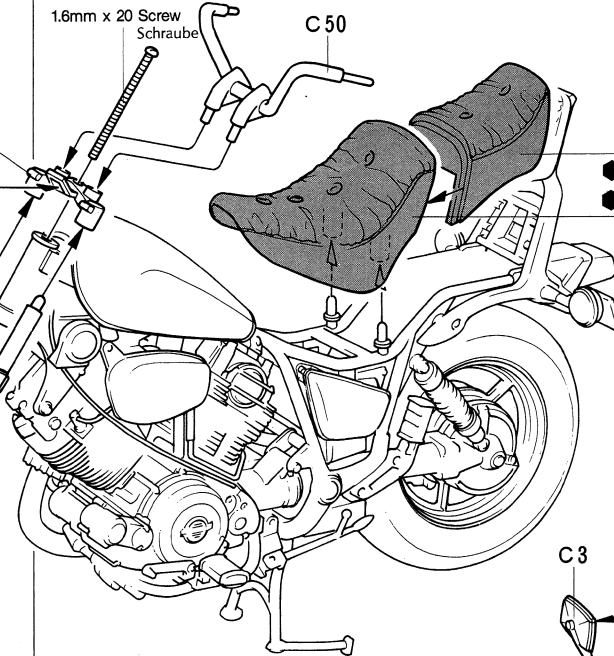

**METER CABLE TACHOKABEL**

Pass meter cable between C37 and B19. Kabel zwischen C37 + C19 durchföhren.

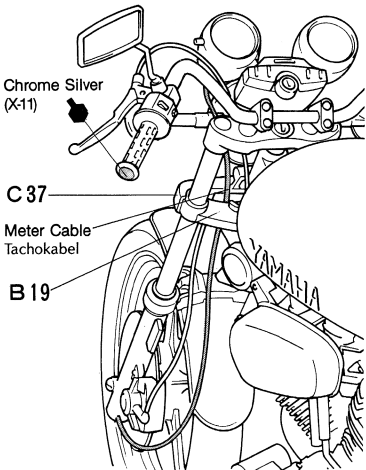

**Attaching Meter Kabel-Einbau**

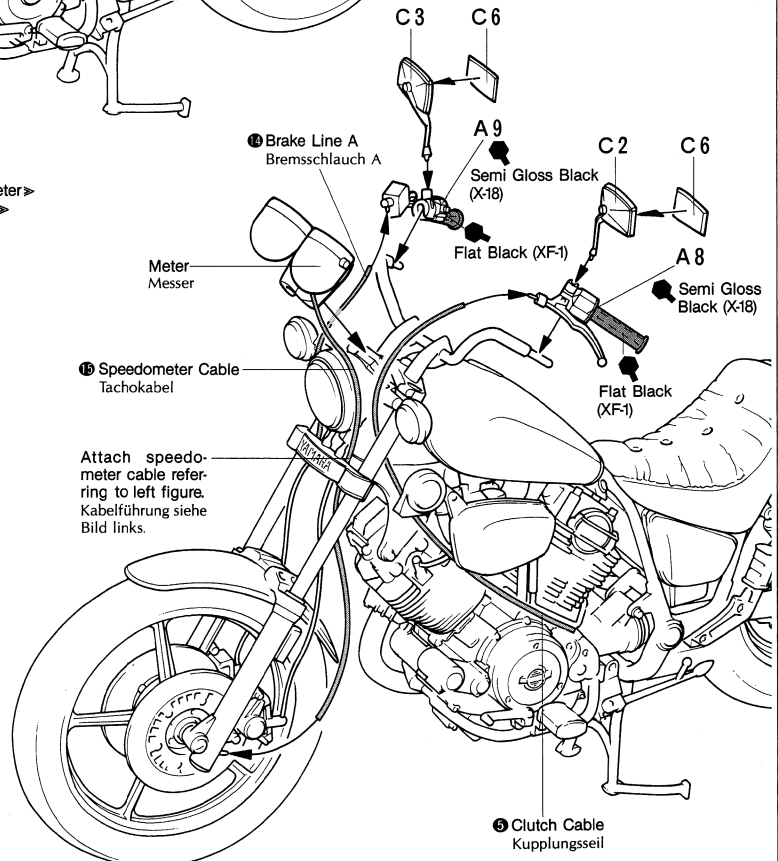

# PAINTING

## PAINTING OF THE YAMAHA XV1000 VIRAGO

The Yamaha Corporation offers the Virago XV1000 in a Romanesque Crimson for the fuel tank and side covers. The rest of the bike is chrome with some gold trim. The gold parts are simulated on the model by painting the plated area with clear yellow (X-24) Tamiya Acrylic paints. Detail painting is called out during construction and should be done at that time.

**BEMALUNG DER YAMAHA XV1000 VIRAGO**  
Yamaha bietet die Virago XV1000 mit römisch-karminroten Tank und Seiten-Abdeckung an. Die übrigen Teile sind in Chrome mit einigen goldfarbenen Zierleisten. Diese Verzierungen können auf den verchromten Flächen mit Clear yellow (X-24) der TAMIYA Acryl-Farben gemalt werden. Bemalung kleiner Detail sind in den einzelnen Baustufen angegeben und sollten auch sofort gemacht werden.

### COLORS REQUIRED: FOLGEBE FARBEN WERDEN BENÖTIGT:

★From Tamiya Acrylic Paints

|                        |       |
|------------------------|-------|
| Black .....            | X-1   |
| Blue .....             | X-4   |
| Green .....            | X-5   |
| Orange .....           | X-6   |
| Red .....              | X-7   |
| Semi Gloss Black ..... | X-18  |
| Clear Yellow .....     | X-24  |
| Clear Orange .....     | X-26  |
| Clear Red .....        | X-27  |
| Flat Black .....       | XF-1  |
| Flat Aluminum .....    | XF-16 |

★From Tamiya Paint Markers

|                     |      |
|---------------------|------|
| Chrome Silver ..... | X-11 |
| Gold Leaf .....     | X-12 |
| Maroon              |      |

## BUILD A COLLECTION OF TAMIYA PRECISION MOTORCYCLE MODELS

1/12 HONDA NS500 with  
STARTING RIDER

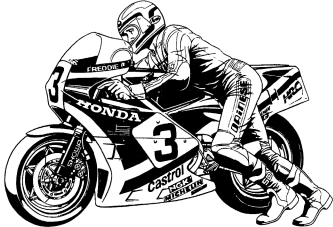

1/12 YAMAHA YZR500(OW70)  
with STRAIGHT RUN RIDER

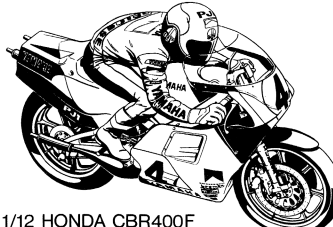

1/12 HONDA CBR400F  
ENDURANCE SPECIAL  
EDITION

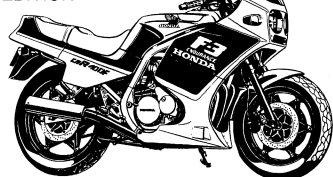

**TAMIYA**  
TAMIYA, INC.  
3-7, ONDWARA, SHIZUOKA-CITY, JAPAN.

## PAINTING AND MARKING OF XV1000 VIRAGO

Body Color: Maroon  
Lettering: Gold Leaf (X-12)

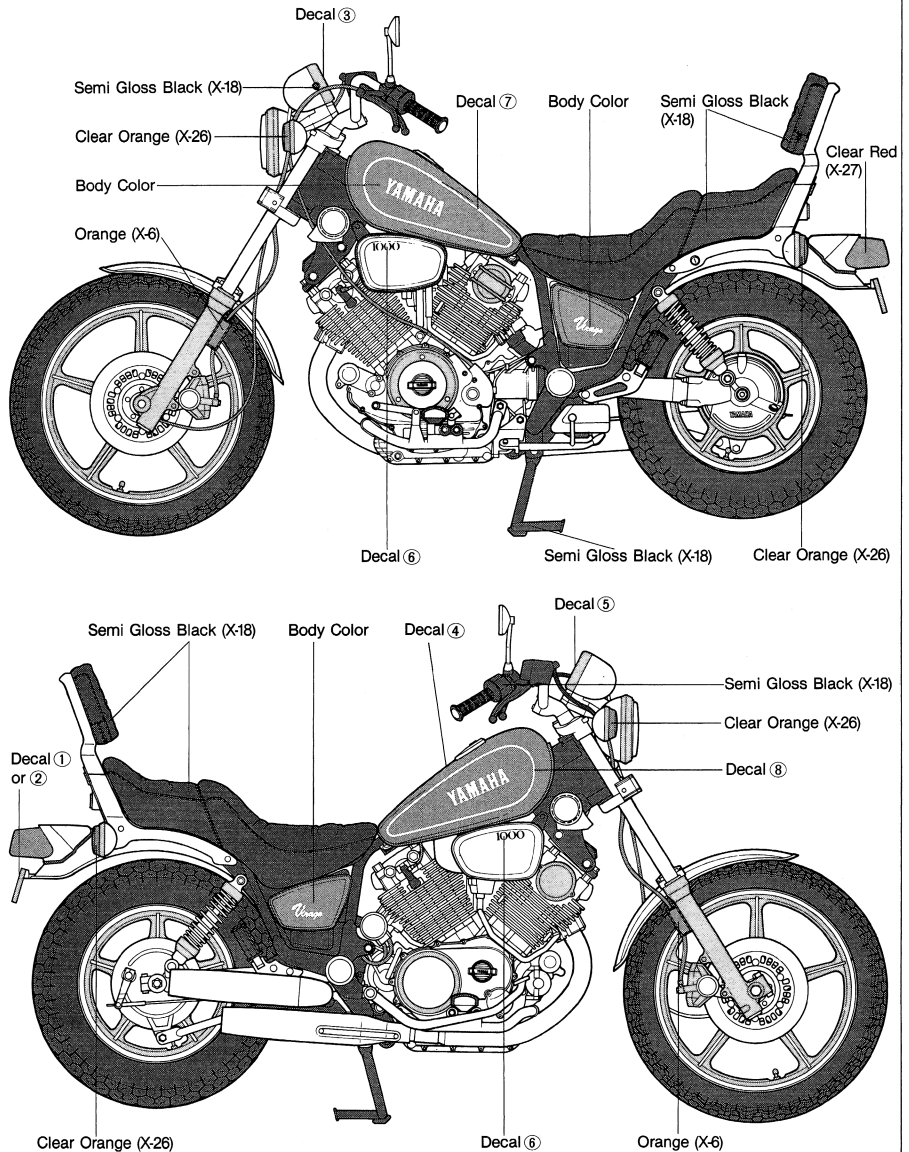

## APPLYING DECALS

### DECAL APPLICATION

- (1) Remove all dust, dirt and adhesive smears with a wet cloth before applying any decals.
- (2) The decal to be applied should be removed beforehand from the decal sheet. Cut off translucent film along colored parts.
- (3) Dip the decal in tepid water for about 10 seconds and then remove it to a clean cloth. Be careful of over immersion to avoid loss of decal's adhesive.
- (4) Hold the backing sheet edge and slide the decal onto the model.
- (5) Wet the decal with a little water on your finger so that it can be moved more easily into position.
- (6) Press the decal down gently with a clean soft cloth to remove air bubbles and until all excess water has been fully absorbed. When a decal has to be applied to a surface which is uneven or curved, press the decal down with a hot towel so that the decal will fit the contours perfectly. Cut off the excess transparent portion around each decal. The decal must then not be touched until dry.

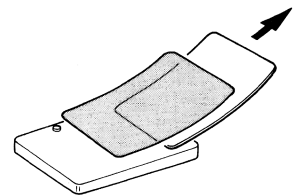

### ABZIEHBILDER - DECALS

- (1) Staub, Schmutz und Klebstoffreste mit nassem Tuch entfernen.
- (2) Decals erst ausschneiden entlang den Linien.
- (3) Decals in Wasser legen, dann nach 10 Sekunden auf z.B. Handtuch legen und etwas abtrocknen lassen.
- (4) Decal an der Unterlage halten und Bild auf das Modell schieben.
- (5) Mit etwas Wasser auf dem Finger lässt sich das Decal noch etwas verschieben.
- (6) Decal mit etwas Stoff gut andrücken um die Luftblasen zu entfernen und das Wasser abzutrocknen. An unebenen Stellen kann man mit heissen Tuch das Decal besser andrücken. Transparente Überreste am Decal abschneiden. Decal nicht mehr berühren, bis getrocknet ist.





1/12 オートバイシリーズNO.44  
ヤマハXV1000ビラーゴ

このモデルは、ヤマハの最新鋭のオートバイを忠実に再現したもので、  
\* READY TO ASSEMBLE PRECISION MODEL KIT  
\* MODELING SKILLS HELPFUL IF UNDER 10 YEARS OF AGE  
\* CEMENT AND PAINT NOT INCLUDED  
※ 塗装別売



\*1/12th SCALE

\*DETAILED AIR COOLED V TWIN ENGINE

**YAMAHA XV1000** *Virago*

**TAMIYA #14044 1:12**

**YAMAHA XV1000** *Virago*



**YAMAHA**

**A475R<sup>NJ</sup><sub>A85</sub>**

